

# EXTENDED-TAB (ET) CONNECTION

## NEW MILL-TYPE E.T. CONNECTION #4A

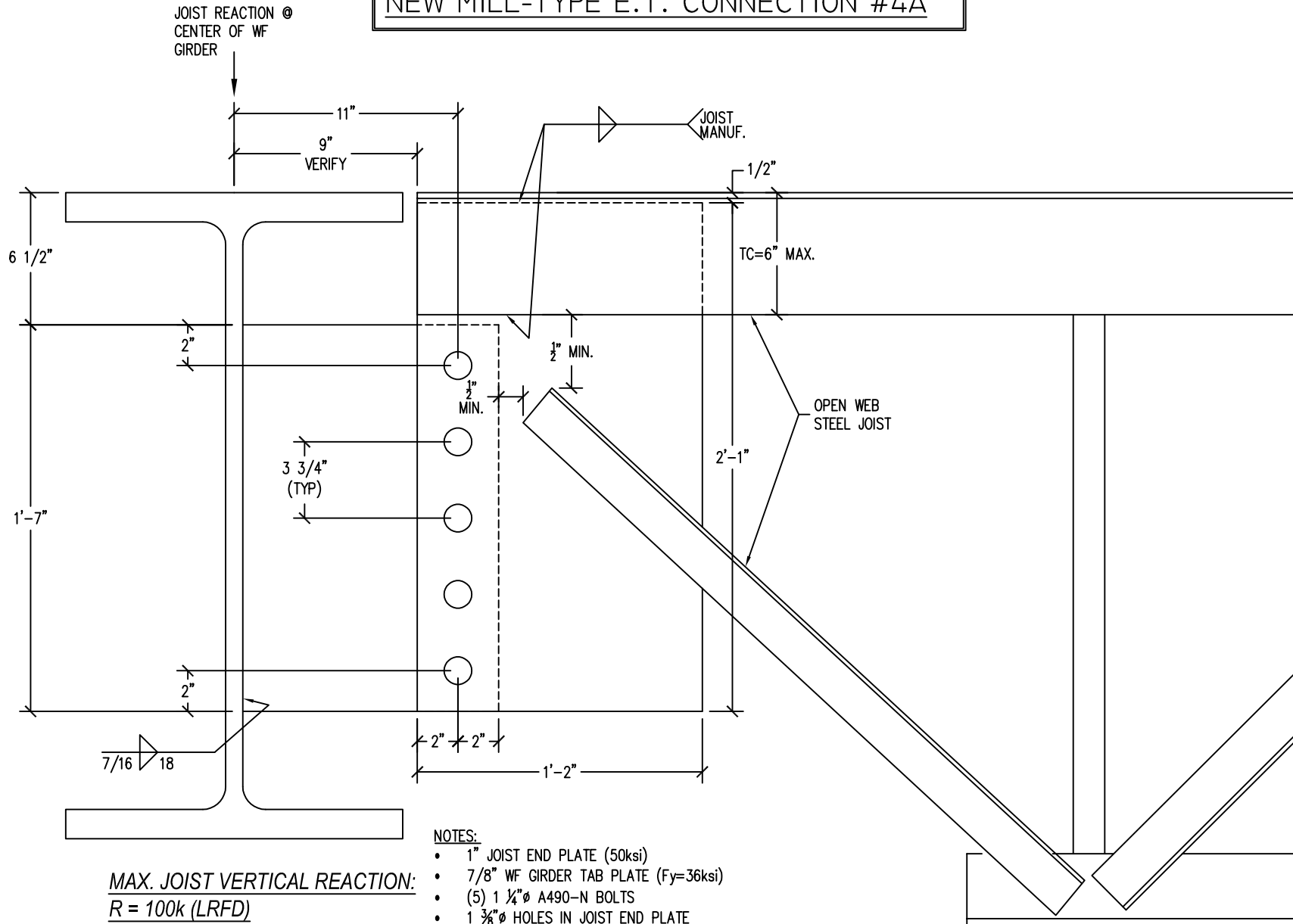

**MAX. JOIST VERTICAL REACTION:**  
 **$R = 100k$  (LRFD)**

**NOTES:**

- 1" JOIST END PLATE (50ksi)
- 7/8" WF GIRDER TAB PLATE ( $F_y=36$ ksi)
- (5) 1 1/4"  $\phi$  A490-N BOLTS
- 1 3/8"  $\phi$  HOLES IN JOIST END PLATE
- 1 3/8" x 1 5/8" SHORT SLOTTED HOLES IN WF GIRDER TAB



**NEW MILLENNIUM**

A Steel Dynamics Company

WWW.NEWMILL.COM

Date: 3/18/2025



# NEW MILLENNIUM

A Steel Dynamics Company

JOB NAME:	JOB #:		
LOCATION:	NMBS E.T. #4A Joist End Plate	DATE:	3/18/2025

### AISC 16TH - p. 10-49 (Extended Configuration)

Holes must satisfy AISC J3.3

Horizontal Axial forces (seismic or wind) if present, to be transferred from beam to joist via tie plate

Joist Plate, $F_u =$	65	ksi	TC Hold Back Distance (H) =	9	in	Joist Plate w =	14	in
Joist Tab Plate, $F_y =$	50	ksi	TC Angle Size =	3.5	in	Joist Plate d =	25	in
Joist Plate, d or w =	14	in	Joist Plate Hold-Down from TC =	0.5	in			
Joist Plate Thickness, t =	1	in						
Joist Plate Edge Distances, de =	2	in						
e =	11	in				$L_{11} =$	7.5	
Vertical Shear, $V_u =$	100	k (LRFD)				$L_{12} =$	3.75	
Vertical Ecc. Moment, $M_u =$	1100	k*in (LRFD)				$L_{13} =$	0	
Bolt Diameter, $D_b =$	1.25	in				$L_{14} =$	0	
Bolt Shear Capacity $\phi R_n =$	62.7	k (A490-N)				$L_{15} =$	0	
# of Bolts, $N_b =$	5	(Spreadsheet design limitation, max. 10 bolts)						
Spacing of Bolt Group, S =	3.75	in						
Vert. C.G. of Bolt Group =	7.5	in						
$F_{nv}/0.9 =$	75.56	ksi (Table J3.2, A490-N Bolts)						
Short Slotted Hole, Lh =	1.63	in (conservative design, allows for slotted holes in joist plate)						
Joist Top Chord Axial Force, $V_{TC} =$	150	k (LRFD)...Assumes 1.5:1 End Web Slope						

Gross Plate Area, $A_g =$	14	in <sup>2</sup>
Effective Plate Area, $A_e =$	12.63	in <sup>2</sup>
Z =	49	in <sup>3</sup> (1/4t*w <sup>2</sup> )
S =	32.6667	in <sup>3</sup> (1/6t*w <sup>2</sup> )

#### Bolt Shear - Elastic Vector Method: (AISC p. 7-7, 7-8)

Bolt Group $I_p =$	140.63	in <sup>4</sup> /in <sup>2</sup>
$r_{py} =$	20.00	k (Vu/# Bolts)
$r_{mx} =$	58.67	k ( $M_u * L_{11} / I_p$ )
Hm =	58.67	k ( $r_{mx} * N_c$ ) $N_c = 1$ column of bolts
$R_u =$	61.98	k ( $r_{py}^2 + r_{mx}^2$ ) <sup>1/2</sup>
$R_u / \phi R_n =$	0.99	< 1.0 OK

#### Bolt Bearing & Tearout: (AISC J3.11)

Bearing $R_{nb} =$	195.00	k/bolt ( $2.4 * D_b * t * F_u$ ) AISC J3-6a
$L_{ch} =$	1.19	in ( $d_e - L_h / 2$ )
Horizontal Tearout $R_{nt} =$	92.63	k/bolt ( $1.2 * L_{ch} * t * F_u$ ) AISC J3-6c
$R_u =$	61.98	k (worst case bolt shear)
$r_{mx} =$	58.67	k (worst case horiz. bolt shear)
$\phi =$	0.75	(AISC J3.11)
Bearing $R_u / \phi R_{nb} =$	0.42	< 1.0 OK
Tearout $r_{mx} / \phi R_{nt} =$	0.84	< 1.0 OK

Stress Ratio Results:	
Bolt Shear (V&M):	0.99
Bolt Bearing & Tearout:	0.84
Shear Plate Rupture:	0.39
Shear Plate Block Shear:	0.34
Shear Plate Flexural Rupture:	0.50
Shear Plate Yielding & Flexural:	0.31

Min. Joist TC to Plate Weld:

2 /16th x 13.5 " Fillet Weld

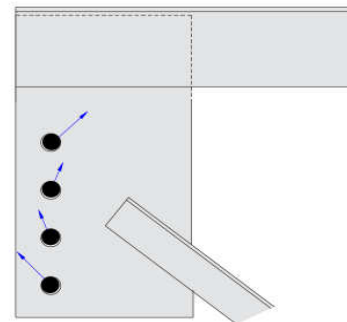

NOTE: FOR VISUAL FORCE SCHEMATIC ONLY



# NEW MILLENNIUM

A Steel Dynamics Company

JOB NAME:	JOB #:		
LOCATION:	NMBS E.T. #4A Joist End Plate	DATE:	3/18/2025

### Shear Plate Rupture: (AISC J4.2)

Crushed Hole Width,  $W' = 1.4375$  in (plate hole + 1/16" Crushed width)  
 Net Plastic Modulus,  $Z_{net} = 39.97$  in<sup>3</sup> ( $Z - W'*t*d_{hole}$ )  $d_{hole} = 6.28125$   
 $\phi V_n = 369.28$  k ( $\phi = 0.75, \phi*0.60*F_u*A_e$ ) AISC J4-4  
 $\phi M_n = 1948.57$  k\*in ( $\phi = 0.75, \phi*F_u*Z$ )  
 $R_u / \phi R_n = 0.39 < 1.0$  OK ( $(V_u/\phi V_n)^2 + (M_u/\phi M_n)^2$ )

### Shear Plate Block Shear: (AISC J4.3)

Vertical Direction

Gross Area in Shear,  $A_{gv} = 17.00$  in<sup>2</sup> ( $t*(d_e + (N_b - 1)*S$ )  
 Net Area in Shear,  $A_{nv} = 9.81$  in<sup>2</sup>  $A_{gv} - (N_b*W')$ \*t  
 Net Area in Tension,  $A_{nt} = 1.19$  in<sup>2</sup> ( $t*(d_e - L_h/2)$ )  
 Gross Area,  $\phi R_n = 440.39$  k ( $0.75*(0.6*F_y*A_{gv} + U_{bs}*F_u*A_{nt})$ )  $U_{bs} = 1.0$  for single bolt line  
 Net Area,  $\phi R_n = 344.91$  k ( $0.75*(0.6*F_u*A_{nv} + U_{bs}*F_u*A_{nt})$ ) AISC J4-5

Note: Use of Lh for determination of Net Plate Area, allows for the slots to be in either the joist end plate or the beam tab.

Horizontal Direction

Gross Area in Shear,  $A_{gv} = 4.00$  in<sup>2</sup> ( $2*t*d_e$ )  
 Net Area in Shear,  $A_{nv} = 2.38$  in<sup>2</sup> ( $2*t*(d_e - L_h/2)$ )  
 Net Area in Tension,  $A_{nt} = 9.25$  in<sup>2</sup> ( $t*((N_b - 1)*S - (N_b - 1)*W)$ )  
 Gross Area,  $\phi R_n = 540.94$  k ( $0.75*(0.6*F_y*A_{gv} + U_{bs}*F_u*A_{nt})$ )  $U_{bs} = 1.0$  for single bolt line  
 Net Area,  $\phi R_n = 520.41$  k ( $0.75*(0.6*F_u*A_{nv} + U_{bs}*F_u*A_{nt})$ ) AISC J4-5

Note: Use of Lh for determination of Net Plate Area, allows for the slots to be in either the joist end plate or the beam tab.

$\phi R_n = 344.91$  k Controls  
 $R_u / \phi R_n = 0.34 < 1.0$  OK ( $(V_u^2 + H_m^2)^{1/2} / \phi R_n$ )

### Shear Plate Flexural Rupture: (AISC F11)

Yielding  $M_c = 2205.0$  k\*in ( $\phi = 0.9, \phi*(F_y*Z < 1.5F_y*S)$ ) AISC F11-1  
 Lateral-Torsional Buckling Check: 154.0  $L_b*d/t^2, L_b = e$  Check for Lateral Torsional Buckling per AISC F11-3  
 Lateral-Torsional Buckling,  $M_c = 2205$  k\*in AISC F11-3  
 $R_u / \phi R_n = 0.50 < 1.0$  OK ( $M_u/M_c$ )

### Shear Plate Yielding & Flexural Strength: (AISC 10-8)

$V_c = 420$  k ( $\phi = 1.0, \phi*0.6*F_y*Ag$ ) AISC J4-3  
 Yielding  $M_c = 2205$  k\*in ( $\phi = 0.9, \phi*(F_y*Z < 1.5F_y*S)$ ) AISC F11-1  
 Lateral-Torsional Buckling Check: 154.0  $L_b*d/t^2, L_b = e$  Check for Lateral Torsional Buckling per AISC F11-3  
 Lateral-Torsional Buckling,  $M_c = 2205$  k\*in AISC F11-3  
 $R_u / \phi R_n = 0.31 < 1.0$  OK ( $(V_u/V_c)^2 + (M_u/M_c)^2$ ) AISC 10-8

### Joist Plate Weld (Angle = 0 deg. & C<sub>1</sub> = 1.00 E70 Electrode):

Length of Plate Weld  $L_w = 13.5$  in (w-0.5")  
 $a_y = 0.1$  AISC Table 8-4  $a_y = (\text{Weld Centroid} - \text{TC Centroid}) / L_w$   
 $k_y = 0.3$  AISC Table 8-4  $k_y = \text{Weld Spacing} / L_w$   
 $C_y = 3.71$  (y-axis weld eccentricity, AISC Table 8-4)  
 $D_{min} = 2$  /16ths of an inch Fillet Weld Size (min)

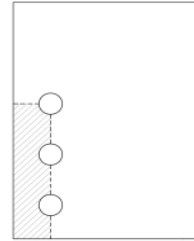

NOTE: SCHEMATIC ONLY. HOLES OR PLATE MAY VARY

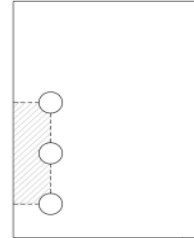



# NEW MILLENNIUM

A Steel Dynamics Company

JOB NAME:	JOB #:		
LOCATION:	NMBS Beam Tab E.T. #4A	DATE:	3/18/2025

### AISC 16TH - p. 10-49 (Extended Configuration)

Holes must satisfy AISC J3.3

Horizontal Axial forces (seismic or wind) if present, to be transferred from beam to joist via tie plate

Beam Tab Plate, $F_u$ =	58	ksi	
Beam Tab Plate, $F_y$ =	36	ksi	
Beam Tab Plate Depth, $d$ =	19	in	
Beam Tab Thickness, $t$ =	0.875	in	
Beam Tab Edge Distances, $d_e$ =	2	in	$L_{11} = 7.5$
$e$ =	11	in	$L_{12} = 3.75$
Vertical Shear, $V_u$ =	100	k (LRFD)	$L_{13} = 0$
Vertical Ecc. Moment, $M_u$ =	1100	k*in (LRFD)	$L_{14} = 0$
Bolt Diameter, $D_b$ =	1.25	in	$L_{15} = 0$
Bolt Shear Capacity $\phi R_n$ =	62.7	k	
# of Bolts, $N_b$ =	5	(Spreadsheet design limitation, max. 10 bolts)	
Spacing of Bolt Group, $S$ =	3.75	in	
C.G. of Bolt Group =	7.5	in	
$F_{nv}/0.9$ =	75.56	ksi (Table J3.2, A490-N Bolts)	
Short Slotted Hole, $L_h$ =	1.63	in	

$A_b$ =	1.23	in <sup>2</sup> (Bolt Area)
$C'$ =	21.43	AISC Eq. 7-17
$M_{max}$ =	1987.46	k*in ( $F_{nv}/0.9 * A_b * C'$ , Eq. 10-7)

**Max. Beam Tab Thickness,  $t_{max}$  = 0.92 in ( $6 * M_{max} / (F_y * d^2)$ ) AISC Eq. 10-6**

Gross Plate Area, $A_g$ =	16.625	in <sup>2</sup>
Effective Plate Area, $A_e$ =	10.61	in <sup>2</sup>
$Z$ =	78.9688	in <sup>3</sup> ( $1/4t * d^2$ )
$S_{net}$ =	52.65	in <sup>3</sup> ( $1/6t * d^2$ )

#### Bolt Shear - Elastic Vector Method: (AISC p. 7-7, 7-8)

Bolt Group $I_p$ =	140.63	in <sup>4</sup> /in <sup>2</sup>
$r_{py}$ =	20.00	k (Vu/# Bolts)
$r_{mx}$ =	58.67	k ( $M_u * L_{11} / I_p$ )
$H_m$ =	58.67	k ( $r_{mx} * N_c$ ) $N_c = 1$ column of bolts
$R_u$ =	61.98	k ( $(r_{py}^2 + r_{mx}^2)^{1/2}$ )
$R_u / \phi R_n$ =	0.99	< 1.0 OK

#### Bolt Bearing & Tearout: (AISC J3.11)

Bearing $R_{nb}$ =	152.25	k/bolt ( $2.4 * D_b * t * F_u$ ) AISC J3-6a
$L_{ch}$ =	1.19	in ( $d_e - L_h / 2$ )
Horizontal Tearout $R_{nt}$ =	72.32	k/bolt ( $1.2 * L_{ch} * t * F_u$ ) AISC J3-6c
$R_u$ =	61.98	k (worst case bolt shear)
$r_{mx}$ =	58.67	k (worst case horiz. bolt shear)
$\phi$ =	0.75	(AISC J3.11)
Bearing $R_u / \phi R_{nb}$ =	0.54	< 1.0 OK
Tearout $r_{mx} / \phi R_{nt}$ =	1.08	< 1.5/1.2 O.K. Deformation at hole may occur

Stress Ratio Results:	
Bolt Shear (V&M):	0.99
Bolt Bearing & Tearout:	1.08 O.K.
Shear Tab Rupture:	0.36
Shear Tab Block Shear:	0.43
Shear Tab Flexural Rupture:	0.43
Shear Tab Yielding & Flexural:	0.26
7 /16" Tab Weld:	0.27
Plate Stability Acceptable	

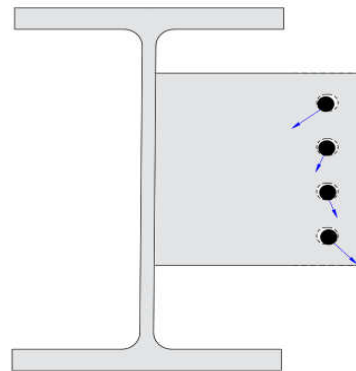

NOTE: FOR VISUAL FORCE SCHEMATIC ONLY



**NEW MILLENNIUM**

A Steel Dynamics Company

JOB NAME:	JOB #:		
LOCATION:	NMBS Beam Tab E.T. #4A	DATE:	3/18/2025

**Shear Tab Rupture:** (AISC J4.2)

Crushed Hole Width,  $W' = 1.4375$  in (plate hole + 1/16" Crushed width)  
 Net Plastic Modulus,  $Z_{net} = 53.25$  in<sup>3</sup> (Summation of A\*d of net plate section)  
 $\phi V_n = 276.90$  k ( $\phi = 0.75, \phi * .60 * F_u * A_e$ ) AISC J4-4  
 $\phi M_n = 2316.42$  k\*in ( $\phi = 0.75, \phi * F_u * Z$ )  
 $R_u / \phi R_n = 0.36 < 1.0$  OK ( $(V_u / \phi V_n)^2 + (M_u / \phi M_n)^2$ )

**Shear Tab Block Shear:** (AISC J4.3)

Vertical Direction

Gross Area in Shear,  $A_{gv} = 14.88$  in<sup>2</sup> ( $t * (d_e + (N_b - 1) * S)$ )  
 Net Area in Shear,  $A_{nv} = 8.59$  in<sup>2</sup> ( $A_{gv} - (N_b * W')$ ) \* t  
 Net Area in Tension,  $A_{nt} = 1.04$  in<sup>2</sup> ( $t * (d_e - L_h / 2)$ )  
 Gross Area,  $\phi R_n = 286.17$  k ( $0.75 * (0.6 * F_y * A_{gv} + U_{bs} * F_u * A_{nt})$ )  $U_{bs} = 1.0$  for single bolt line  
 Net Area,  $\phi R_n = 269.29$  k ( $0.75 * (0.6 * F_u * A_{nv} + U_{bs} * F_u * A_{nt})$ ) AISC J4-5

Horizontal Direction

Gross Area in Shear,  $A_{gv} = 3.50$  in<sup>2</sup> ( $2 * t * d_e$ )  
 Net Area in Shear,  $A_{nv} = 2.08$  in<sup>2</sup> ( $2 * t * (d_e - L_h / 2)$ )  
 Net Area in Tension,  $A_{nt} = 8.09$  in<sup>2</sup> ( $t * ((N_b - 1) * S - (N_b - 1) * W)$ )  
 Gross Area,  $\phi R_n = 408.78$  k ( $0.75 * (0.6 * F_y * A_{gv} + U_{bs} * F_u * A_{nt})$ )  $U_{bs} = 1.0$  for single bolt line  
 Net Area,  $\phi R_n = 406.32$  k ( $0.75 * (0.6 * F_u * A_{nv} + U_{bs} * F_u * A_{nt})$ ) AISC J4-5

$\phi R_n = 269.29$  k Controls  
 $R_u / \phi R_n = 0.43 < 1.0$  OK ( $(V_u^2 + H_m^2)^{1/2} / \phi R_n$ )

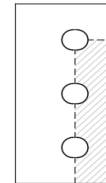

NOTE: SCHEMATIC ONLY, HOLES MAY VARY

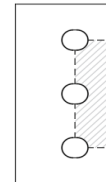

**Shear Tab Flexural Rupture:** (AISC F11)

Yielding  $M_c = 2558.6$  k\*in ( $\phi = 0.9, \phi * (F_y * Z < 1.5 F_y * S)$ ) AISC F11-1  
 Lateral-Torsional Buckling Check: 273.0  $L_b * d / t^2$ ,  $L_b = e$  Check for Lateral Torsional Buckling per AISC F11-3  
 Lateral-Torsional Buckling,  $M_c = 2558.6$  k\*in AISC F11-3  
 $R_u / \phi R_n = 0.43 < 1.0$  OK ( $M_u / M_c$ )

**Shear Tab Yielding & Flexural Strength:** (AISC 10-8)

$V_c = 359.1$  k ( $\phi = 1.0, \phi * 0.6 * F_y * A_g$ ) AISC J4-3  
 Yielding  $M_c = 2558.6$  k\*in ( $\phi = 0.9, \phi * (F_y * Z < 1.5 F_y * S)$ ) AISC F11-1  
 Lateral-Torsional Buckling Check: 273.0  $L_b * d / t^2$ ,  $L_b = e$  Check for Lateral Torsional Buckling per AISC F11-3  
 Lateral-Torsional Buckling,  $M_c = 2558.6$  k\*in AISC F11-3  
 $R_u / \phi R_n = 0.26 < 1.0$  OK ( $(V_u / V_c)^2 + (M_u / M_c)^2$ ) AISC 10-8

**Shear Tab Weld:**

Min. Weld Thickness  $t_{wmin} = 0.39$  in.  $t_{wmin} = (t * F_y * 3^{1/2}) / (2 * F_{EXX})$ ,  $F_{EXX} = 70$ ksi Electrode, AISC Engineering Journal, Vol. 46, 2009  
 Weld Provided  $t_w = 0.4375$  in  
 Min. Plate Thickness = 0.75 in (AISC Eq. 9-7,  $6.19 * D / F_u$ ) **GOOD**  
 $\phi R_w = 370.25$  k ( $\phi * 0.6 * F_{EXX} * 0.707 * t_w * d * 2$ )  
 $R_u / \phi R_n = 0.27 < 1.0$  OK

**Shear Tab Stability:** (Thorton and Fortney, 2011)

**Lateral Torsional Buckling Check:**

$\phi R_n = 446$  k **Acceptable**

$$R_{req'd} \leq \phi R_n \text{ (LRFD)}$$

$$R_n = 1500 \pi \frac{l^3}{a^2}$$

$l$  = beam tab plate length (depth)  
 $t$  = tp = beam tab plate thickness  
 $a$  = Eccentricity 'e'

**Lap Splice Eccentricity Check:**

$\phi M_{t,u} = 113.4$  k\*in  
 $M_{t,u} = 93.8$  k\*in ( $R * (t_p + t_t) / 2$ )

$$\phi_{t,u} \leq \left[ \phi_v \left( U_{bs} F_u \right) \right] \frac{R_M}{t_p} \frac{t_p^2}{2} \quad \phi_v = 1.0$$

(LRFD)

**Acceptable**